

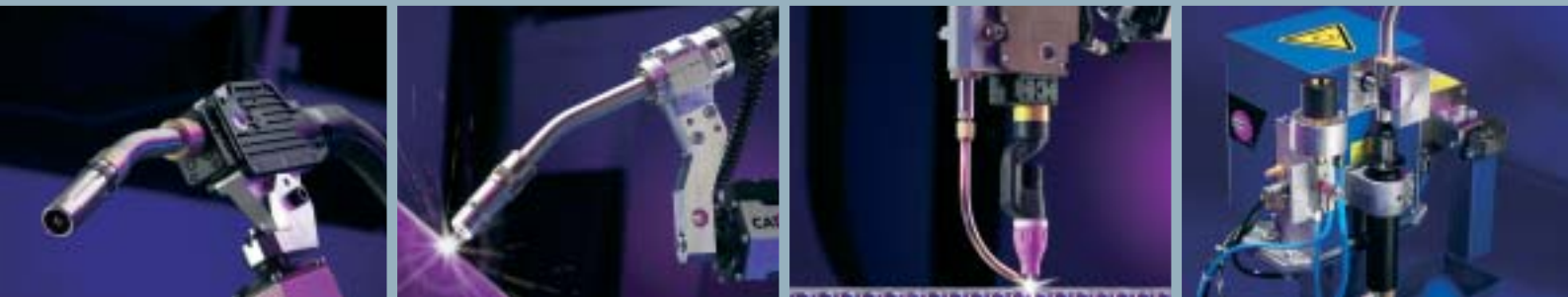

ROBO



Catalogue 2006/2007

Technology for the Welder's World.



Finally, periphery that completes the efficiency of a robot work cell.

In the late seventies ABICOR BINZEL started with the development of systems for robotic welding parallel to the introduction of the first robots in the automotive industry.

Today ABICOR BINZEL provides an effective product range of robot torches and corresponding peripheral items which are in use around the world, 24 hours a day.

Accompanying the product, a team of experts, both in our headquarter and in our subsidiaries, is always ready to assist with standard and custom-specific solutions. Besides the installation, application and special training our after-sales service includes the support and optimization of the production process. Quick spare part supply and repairs are included.

To recognize and to co-create new innovative technological trends, is one of our strong points.

Automatic welding with ABICOR BINZEL

Founded in 1945 the Alexander Binzel Schweisstechnik GmbH & Co. KG specialized in the development and production of welding and cutting torches for the GMAW (Gas Metal Arc Welding), GTAW (Gas Tungsten Arc Welding) and Plasma processes.

Numerous patented developments help shape the world of welding and cutting and set international standards.

The ABICOR BINZEL group is represented in more than 50 countries with over 800 employees, 30 production and sales companies, as well as over 20 exclusive partners.

Main production is located in the parent company in Buseck near Giessen, in Dresden, as well as in the USA, Brazil, India and China.

The brand name ABICOR has been established in 1997 as an impression of a company strategy that puts on innovation and globalization and that pursues a clear brand policy.

Content

MIG/MAG Welding Torches

- MIG/MAG Welding Torches "ABIROB® A ECO" air-cooled Page 4–7
ABIROB® A360 / ABIROB® A500
- MIG/MAG Welding Torches "VTS-Interlock" liquid-cooled Page 8–11
ROBO VTS 290 / ROBO VTS 500 TS
- MIG/MAG Welding Torches "WH und WH-PP" liquid-cooled Page 12–15
ROBO WH 242 D / ROBO WH 455 D / ROBO WH 652 D TS

TIG Welding Torches

- TIG Welding Torch System „ABITIG® WH“ liquid-cooled Page 16–19
ABITIG® WH 220 W / ABITIG® WH 400 W

Robot Periphery

- **Robot Mount "CAT2"** Page 20–21
"To absorb collisions easily ..."
- **Torch Cleaning Station "BRS-CC"** Page 22–23
"Plug and Play ..."
- **Front Injector "ABIROB® TMS-VI"** Page 24
"For the reduction of spatter adhesion ..."
- **Wire Cutting Station "DAV"** Page 25
"The perfect cut ..."
- **Neck change torch system "ATS-Rotor"** Page 26–27
„Work around the clock ...“

Welding Accessories

- Anti Spatter Spray, Wire Cleaning Set, Special Coolant, etc. Page 28

Cooling Recirculators

- WK 23 / WK 43 Page 29

MIG/MAG Welding Torches "ABIROB® A ECO" air-cooled

"Air-cooled and effective ..."

The product line ABIROB® A ECO – groundbreaking in its design, trend-setting in standardization – guarantees a continuously precise and economic welding process by its robust construction and simple handling.

- Simple and compact modular design – easy to service
- Slim design – optimal accessibility
- High stability and reproducibility – maximum TCP-safety – even in the event of a "crash"
- Innovative Interlock-system – smooth and quick exchange of the cable assembly at constant TCP
- Available in 360 A & 500 A (at 100 % Duty cycle)

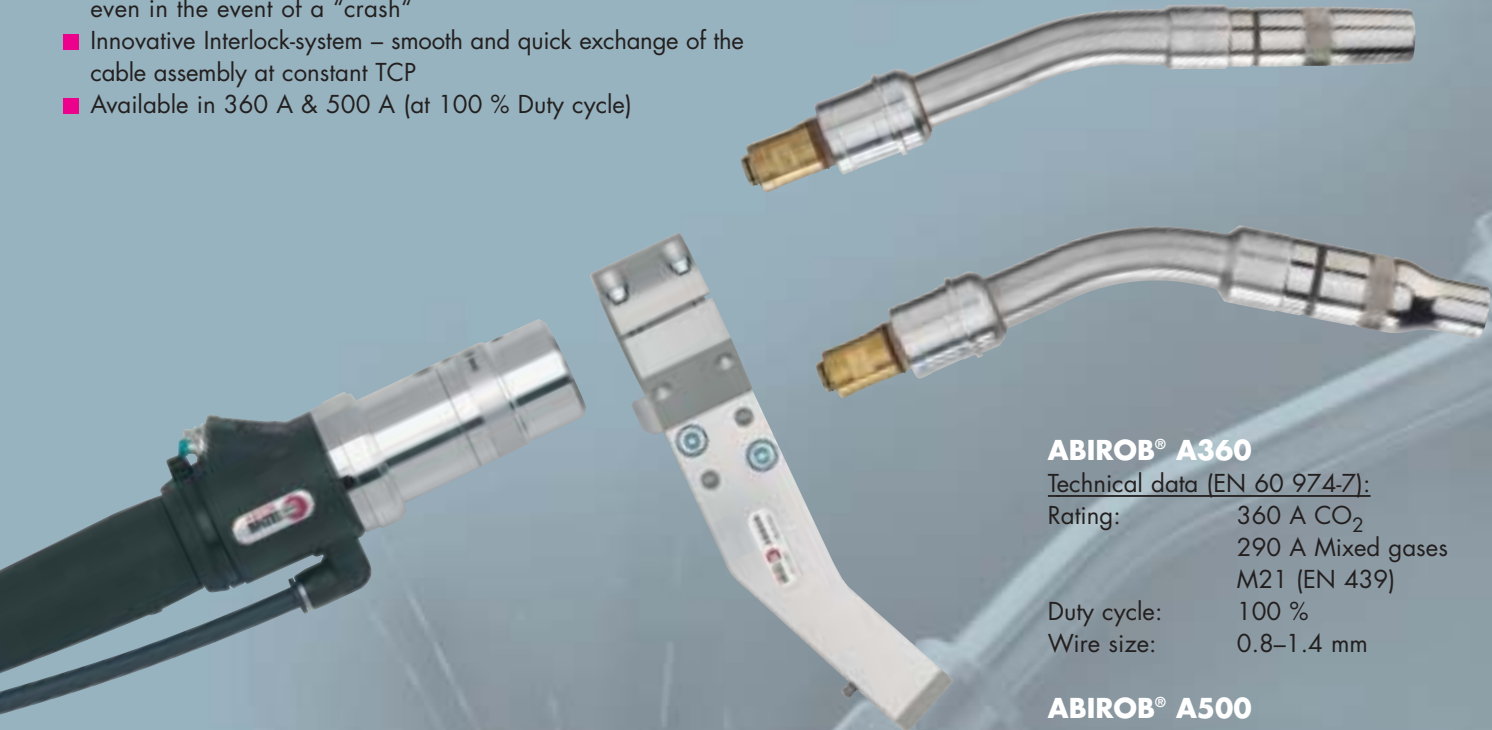

ABIROB® A360

Technical data (EN 60 974-7):

Rating: 360 A CO₂
290 A Mixed gases
M21 (EN 439)

Duty cycle: 100 %

Wire size: 0.8–1.4 mm

ABIROB® A500

Technical data (EN 60 974-7):

Rating: 500 A CO₂
400 A Mixed gases
M21 (EN 439)

Duty cycle: 100 %

Wire size: 0.8–1.6 mm

Swanneck Type	Part-No.			
	straight	22° bend	35° bend	45° bend
ABIROB® A360	980.1023	980.1024	980.1025	980.1026
ABIROB® A500	980.1012	980.1013	980.1014	980.1015

Wear and spare parts are not included in the delivery! Please order separately and according to the application!

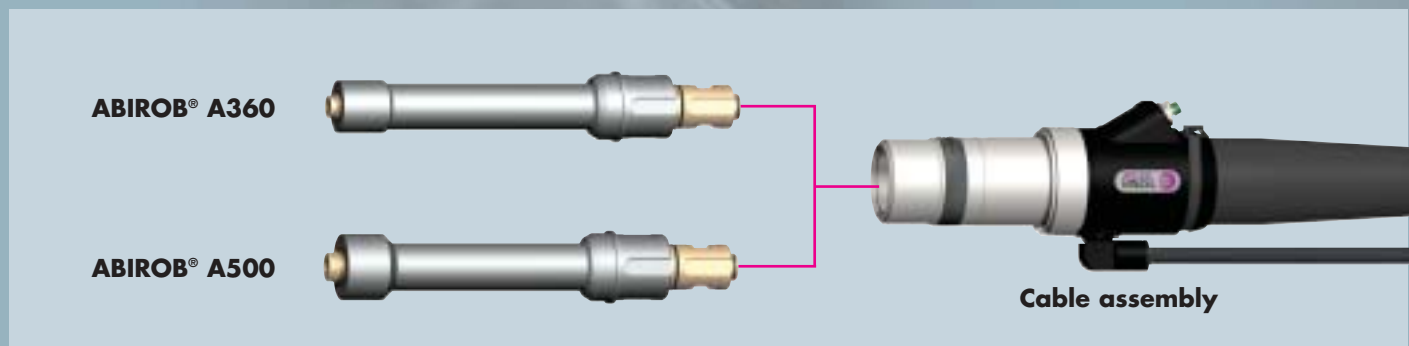

Cable assembly

ABIROB® A360, ABIROB® A500

Wear parts

ABIROB® A360

ABIROB® A500

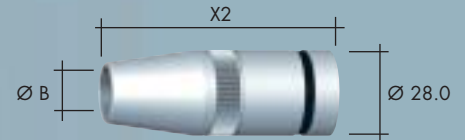
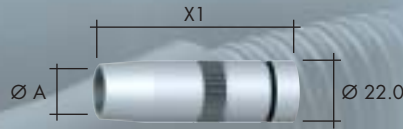

Gas nozzle (5 pcs.)

	Ø A	X1		Ø B	X2	
Bottle form „FLUSH“ ¹⁾	Ø 12.0	68.0 mm	145.0599	Ø 12.0	-	-
Bottle form „RECESS“ (- 2 mm) ²⁾	Ø 12.0	70.0 mm	145.0600	Ø 12.0	-	-
Bottle form „STICK OUT“ (+ 3 mm) ³⁾	Ø 12.0	65.0 mm	145.0601	Ø 12.0	-	-
Conical „FLUSH“ ¹⁾	Ø 13.0	-	-	Ø 13.0	75.0 mm	145.0589
Conical „RECESS“ (- 2 mm) ²⁾	Ø 13.0	-	-	Ø 13.0	77.0 mm	145.0590
Conical „STICK OUT“ (+ 3 mm) ³⁾	Ø 13.0	-	-	Ø 13.0	72.0 mm	145.0591
Conical „FLUSH“ ¹⁾	Ø 14.0	68.0 mm	145.0595	Ø 14.0	-	-
Conical „RECESS“ (- 2 mm) ²⁾	Ø 14.0	70.0 mm	145.0596	Ø 14.0	-	-
Conical „STICK OUT“ (+ 3 mm) ³⁾	Ø 14.0	65.0 mm	145.0597	Ø 14.0	-	-
Bottle form „FLUSH“ ¹⁾	Ø 14.0	68.0 mm	145.0618	Ø 14.0	75.0 mm	145.0586
Bottle form „RECESS“ (- 2 mm) ²⁾	Ø 14.0	-	-	Ø 14.0	77.0 mm	145.0587
Bottle form „STICK OUT“ (+ 3 mm) ³⁾	Ø 14.0	65.0 mm	145.0619	Ø 14.0	72.0 mm	145.0588
Conical „FLUSH“ ¹⁾	Ø 16.0	68.0 mm	145.0592	Ø 16.0	75.0 mm	145.0580
Conical „RECESS“ (- 2 mm) ²⁾	Ø 16.0	70.0 mm	145.0593	Ø 16.0	77.0 mm	145.0581
Conical „STICK OUT“ (+ 3 mm) ³⁾	Ø 16.0	65.0 mm	145.0594	Ø 16.0	72.0 mm	145.0582
Bottle form „FLUSH“ ¹⁾	Ø 16.0	-	-	Ø 16.0	75.0 mm	145.0583
Bottle form „RECESS“ (- 2 mm) ²⁾	Ø 16.0	-	-	Ø 16.0	77.0 mm	145.0584
Bottle form „STICK OUT“ (+ 3 mm) ³⁾	Ø 16.0	-	-	Ø 16.0	72.0 mm	145.0585

¹⁾ FLUSH = Gas nozzle flushed

²⁾ RECESS = Gas nozzle standing back

³⁾ STICK OUT = Gas nozzle protruding

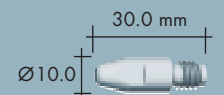
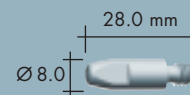
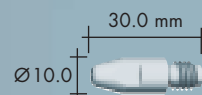
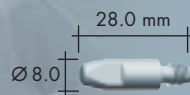

Contact tip (10 pcs.)

		M6	M8	M6	M8
CuCrZr	Ø 0.8	147.0054	147.0117	147.0054	147.0117
silver plated	Ø 0.9	147.0172	147.0217	147.0172	147.0217
	Ø 1.0	147.0245	147.0316	147.0245	147.0316
	Ø 1.2	147.0382	147.0445	147.0382	147.0445
	Ø 1.4	147.0519	147.0536	147.0519	147.0536
	Ø 1.6	-	147.0590	-	147.0590

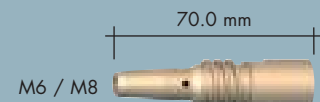
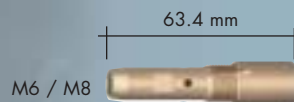

Contact tip holder (5 pcs.)

M6	142.0160	142.0159
M8	142.0163	142.0158

MIG/MAG Welding Torches "ABIROB® A ECO" air-cooled

Cable assemblies and accessories

Cable assemblies cpl.

Length "L"	L=1.15 m	L=1.20 m	L=1.30 m	L=1.45 m	L=1.60 m	L=2.15 m	L=3.15 m
Part-No.	980.1066	980.1067	980.1068	980.1069	980.1070	980.1097	980.1098

The control cable is not pre-wired on the machine end. Power source specific types on request.

Dimension "L"

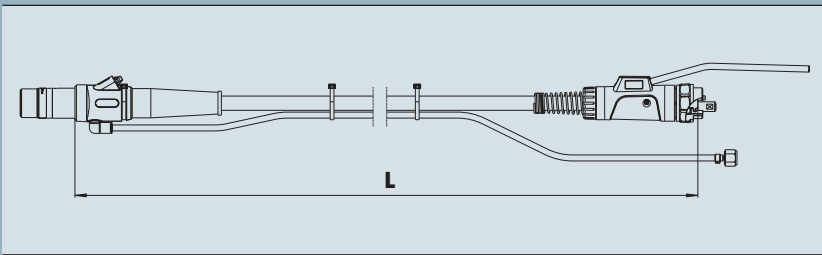

Liner	up to L=2.15 m ²⁾	up to L=3.15 m ²⁾	up to L=10.0 m ³⁾	Collet f.
				liner
Liner ¹⁾ steel red Ø 0.8-1.2	124.0145	124.0146	124.0159	131.0012
Liner ¹⁾ steel white Ø 1.4-1.6	124.0147	124.0148	124.0160	131.0011

¹⁾ **Red and white steel liner** (insulated) for the use of non-alloyed and low-alloyed steels. The totally insulated wire feed prevents damage caused by "micro-arcing" on the wire. This allows optimal current transfer inside the contact tip improving the welding process. The insulated steel liner must be used for power sources with optional welding wire sensors. **Liner** for the use of aluminum and special wire types available on request.

²⁾ Including one collet

³⁾ For individual production including two collets

Mounting arm for connection:

■ to the Robot Mount CAT2

■ directly to the robot

Clamp holder⁴⁾

Segment holder⁴⁾

Fixed bracket⁴⁾

RTM holder⁴⁾



Adjustable TCP definition

Pre-defined angle
in 15°-steps

Fixed defined TCP

To be used at
robots with inte-
grated collision
software, variable
in 15°-steps

⁴⁾ Order-No.: see table page 7

ABIROB® A360, ABIROB® A500

Dimension sketch and alignment jigs

ABIROB® A ECO shown with fixed bracket

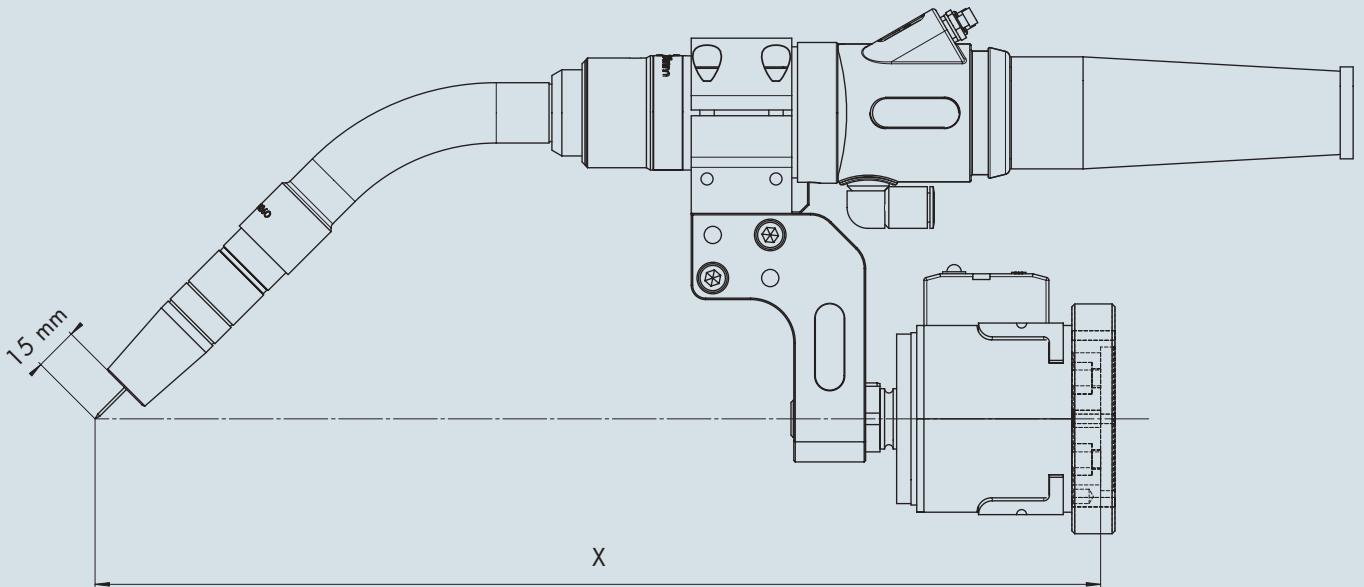

Mounting type	Torch	Torch geometrie	X	Y	Part-No.
Clamp holder	ABIROB® A360 / A500	22°	366	0	780.0259
	ABIROB® A360 / A500	35°	351	0	780.0259
	ABIROB® A360 / A500	45°	338	0	780.0259
Segment holder	ABIROB® A360 / A500	22°	variable in 15°-steps		780.0184
	ABIROB® A360 / A500	35°	variable in 15°-steps		780.0184
	ABIROB® A360 / A500	45°	variable in 15°-steps		780.0184
Fixed bracket	ABIROB® A360 / A500	22°	350	0	780.0268
	ABIROB® A360 / A500	35°	350	0	780.0272
	ABIROB® A360 / A500	45°	350	0	780.0270
RTM holder	ABIROB® A360 / A500	22°	variable in 15°-steps		780.0195
	ABIROB® A360 / A500	35°	variable in 15°-steps		780.0195
	ABIROB® A360 / A500	45°	variable in 15°-steps		780.0195

Other mountings on request.

Alignment jig for torch type	for torch geometrie	Part-No.
ABIROB® A360 / A500	0° / 22° / 45°	837.0500
ABIROB® A360 / A500	35°	837.0514



MIG/MAG Welding Torches "VTS-Interlock" liquid-cooled

"Ease of servicing, stable, flexible ..."

VTS-Interlock – the welding torch system from ABICOR BINZEL for universal, heavy-duty MIG/MAG-Welding – enables a simple and flexible welding torch with different overall sizes and geometries – for changing welding jobs. Standardized interfaces – identical on all VTS modules – guarantee an optimum interchange ability as well as a repeatable TCP installation at the robot or at another welding device.

Reproducible torch position thanks to the "tongue and groove" interlock connection, easy-change torch neck and long-life cable assemblies which are quick to exchange, gives ease of maintenance when servicing the system.

- Flexible adaptation on changing welding jobs
- Standardised interface – interlock connection
- Reproducible torch position
- Liquid-cooled up to 500 A
- Well proven and 100 % reliable



VTS cable assembly

ROBO VTS 290

Technical data (EN 60 974-7):

Rating: 290 A Mixed gases
M21 (EN 439)
Duty cycle: 100 %
Wire size: 0.8–1.2 mm

ROBO VTS 500TS

Technical Data (EN 60 974-7):

Rating: 500 A Mixed gases
M21 (EN 439)
Duty cycle: 100 %
Wire size: 0.8–1.6 mm



"Reproducible Interface"

Interlock connection



Swan neck type	Part-No.			
	0°	22°	35°	45°
ROBO VTS 290	–	785.5050	–	785.5091
ROBO VTS 500TS	785.5101	785.5102	785.5103	785.5104

Wear and spare parts are not included in the delivery! Please order separately and according to the application!

ROBO VTS 290, ROBO VTS 500TS

Wear parts

ROBO VTS 290

ROBO VTS 500TS

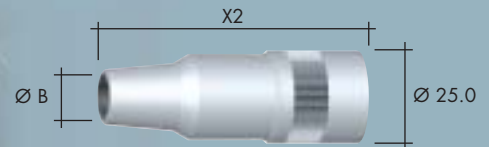
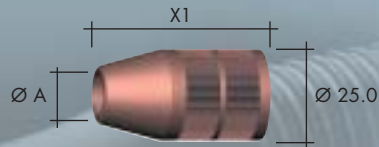

Gas nozzle (5 pcs.)

	Ø A	X1		Ø B	X2	
Conical „RECESS“ (- 1.0 mm) ²⁾	Ø 13.0	48.5 mm	145.0564	Ø 13.0	-	-
Conical „STICK OUT“ (+ 3.0 mm) ³⁾	Ø 13.0	44.5 mm	145.0495	Ø 13.0	-	-
Bottle form „RECESS“ (- 2.6 mm) ²⁾	Ø 13.0	-	-	Ø 13.0	77.0 mm	145.0556
Bottle form „RECESS“ (- 1.1 mm) ²⁾	Ø 13.0	-	-	Ø 13.0	75.5 mm	145.0479
Conical „STICK OUT“ (+ 3.0 mm) ³⁾	Ø 15.5	44.5 mm	145.0494	Ø 15.5	-	-
Bottle form „RECESS“ (- 2.6 mm) ²⁾	Ø 15.5	-	-	Ø 15.5	77.0 mm	145.0480
Bottle form „RECESS“ (- 1.1 mm) ²⁾	Ø 15.5	-	-	Ø 15.5	75.5 mm	145.0544
Bottle form „STICK OUT“ (+ 2.4 mm) ³⁾	Ø 15.5	-	-	Ø 15.5	72.0 mm	145.0466
Conical „RECESS“ (- 1.1 mm) ²⁾	Ø 15.5	-	-	Ø 15.5	75.5 mm	145.0553
Conical „STICK OUT“ (+ 1.9 mm) ³⁾	Ø 15.5	-	-	Ø 15.5	72.5 mm	145.0568

¹⁾ FLUSH = Gas nozzle flushed

²⁾ RECESS = Gas nozzle standing back

³⁾ STICK OUT = Gas nozzle protruding



Contact tip (10 pcs.)

		M6	M6	M8
CuCrZr	Ø 0.8	140.0054	140.0054	140.0117
	Ø 0.9	140.0172	140.0172	140.0217
	Ø 1.0	140.0245	140.0245	140.0316
	Ø 1.2	140.0382	140.0382	140.0445
	Ø 1.4	-	-	140.0536
	Ø 1.6	-	-	140.0590

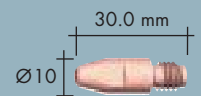
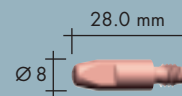
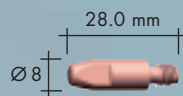

Contact tip holder (10 pcs.)

	M6	M6/M8
M6	785.5052	142.0133
M8	-	142.0117

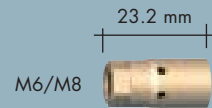
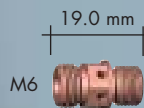

Gas diffuser (10 pcs.)

Nozzle insulator (10 pcs.)

	Gas diffuser	Nozzle insulator
Standard	962.0657	146.0054
High-temperature-resistant	962.1341 (Ceramic)	146.0059

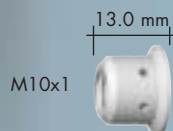

Neck liner

for steel	Ø 0.8-1.2	149.0004	149.0040
	Ø 1.4-1.6	-	149.0043
for Al	Ø 0.8-1.2	149.0013	149.0045
	Ø 1.4-1.6	-	149.0047



MIG/MAG Welding Torches "VTS-Interlock" liquid-cooled

Cable assemblies and accessories

Hybrid cable assembly (cpl.) with Bikox power cable for improved cooling and long life-time

Length "L"	L=1,10 m	L=1,20 m	L=1,35 m	L=1,50 m	L=2,00 m	L=2,65 m	L=3,00 m
Part-No.	785.8020	785.8017	785.8021	785.8018	785.8023	785.8024	785.8025

The control cable is not pre-wired on the machine end. Power source specific types on request.

Dimension "L"

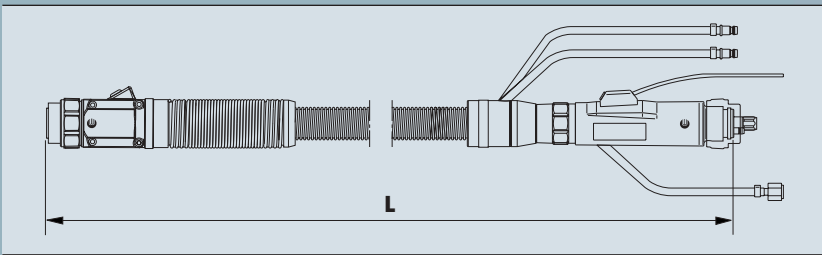

Liner		up to L=2.00 m	up to L=3.00 m
Liner red ¹⁾	Ø 0.8-1.2	-	124.0111
Liner BSLblue ¹⁾	Ø 1.4-1.6	124.0136	124.0108
PA-Liner ²⁾	Ø 0.8-1.2	128.0039	128.0012
Liner ²⁾	Ø 1.4-1.6	128.0040	128.0020

¹⁾ **Red and BSLblue steel liner** (insulated) for the use of non-alloyed and low-alloyed steels. A totally insulated wire feed prevents damage caused by "micro-arcing" on the wire. This allows optimal current transfer inside the contact tip improving the welding process. The insulated steel liner must be used for power sources with optional welding wire sensors.

²⁾ **PA-Liner** for the use of aluminium and special wire types. Good feed ability properties and scratch resistance on the weld wire. Application temperature limit 150° C.

Mounting arm for connection:

■ to the Robot Mount CAT2

■ directly to the robot

Clamp holder ³⁾

Segment holder ³⁾

Fixed bracket ³⁾

RTM holder ³⁾



Adjustable TCP definition

Pre-defined angle in 15°-steps

Fixed defined TCP

To be used at robots with integrated collision software, variable in 15°-steps

³⁾ Order-No.: see table page 11

ROBO VTS 290, ROBO VTS 500TS

Dimension sketch and alignment jigs

ROBO VTS shown with segment holder

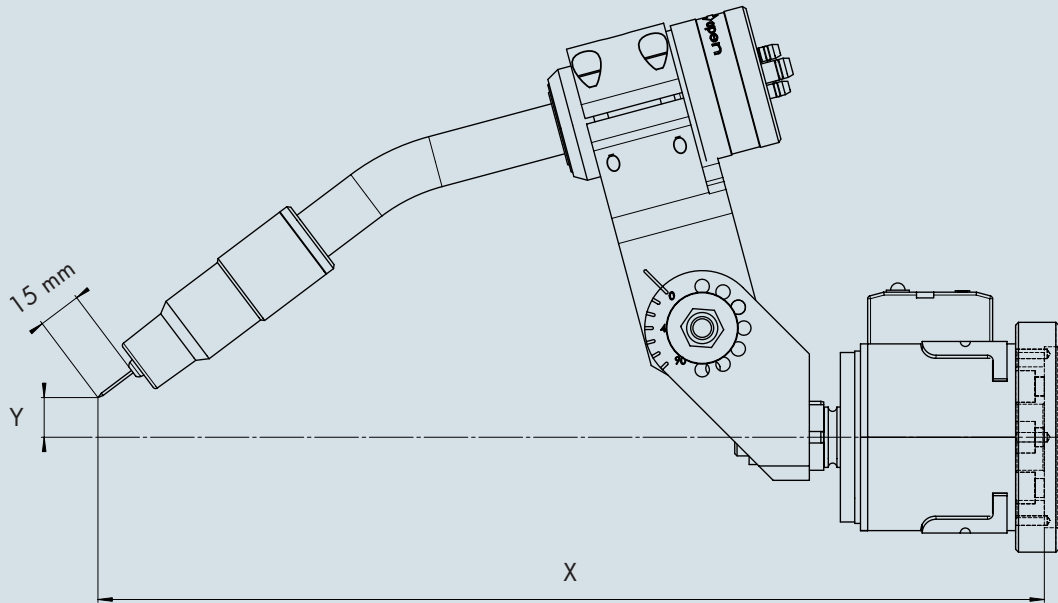

Mounting type	Torch	Torch geometrie	X	Y	Part-No.
Clamp holder	VTS 290	22°	354	0	780.0259
	VTS 290	45°	332	0	780.0259
	VTS 500TS	22°	354	0	780.0259
	VTS 500TS	45°	326	0	780.0259
Segment holder	VTS 290 / VTS 500TS	22°	variable in 15°-steps		780.0184
	VTS 290 / VTS 500TS	45°	variable in 15°-steps		780.0184
Fixed bracket	VTS 500TS	22°	350	0	780.0278
	VTS 500TS	45°	350	0	780.0282
RTM holder	VTS 290 / VTS 500TS	22°	variable in 15°-steps		780.0195
	VTS 500TS	35°	variable in 15°-steps		780.0195
	VTS 290 / VTS 500TS	45°	variable in 15°-steps		780.0195

Other mountings on request.

Alignment jig for torch type	for torch geometrie	Part-No.
ROBO VTS 290	22° / 45°	837.0452
ROBO VTS 500TS	0° / 22° / 45°	837.0464
ROBO VTS 500TS	35°	837.0466

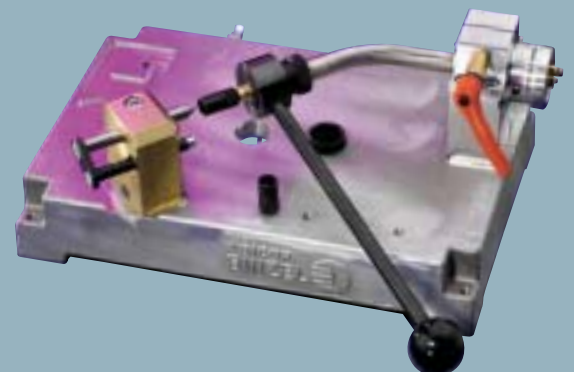

MIG/MAG Welding Torches "WH and WH-PP" liquid-cooled

"Quick adaptation to changing welding tasks ..."

The ABICOR BINZEL neck change torch system makes it possible to replace the complete torch neck by an identical type as well by special geometries for different welding positions in next to no time.

The replacement of contact tip and gas nozzle as well as the monitoring of the TCP also take place outside the welding cell, thus increasing the availability of the system and reducing downtimes.

- Flexible and mobile adaption on changing welding jobs
- Also available as a Push Pull System
- Liquid cooled up to 550 A
- Well proven and 100 % reliable



Quick change body WH



Quick change body WH-PP



ROBO
WH 242 D



ROBO
WH 455 D



ROBO
WH 652 D TS

... fully automatic
torch neck change -
see page 26

ROBO WH 242 D

Technical data (EN 60 974-7):

Rating: 320 A CO₂
280 A Mixed gases
M21 (EN 439)
Duty cycle: 100 %
Wire size: 0.8–1.2 mm

ROBO WH 455 D

Technical data (EN 60 974-7):

Rating: 450 A CO₂
400 A Mixed gases
M21 (EN 439)
Duty cycle: 100 %
Wire size: 0.8–1.6 mm

ROBO WH 652 D TS

Technical data (EN 60 974-7):

Rating: 550 A CO₂
500 A Mixed gases
M21 (EN 439)
Duty cycle: 100 %
Wire size: 1.0–1.6 mm

Swan neck Type	Part-No.		
	0°	22°	45°
ROBO WH 242 D	962.1314	962.1315	962.1316
ROBO WH 455 D	962.0767	962.0768	962.0769
ROBO WH 652 D TS	962.1353	962.1365	962.1366

Wear and spare parts are not included in the delivery! Please order separately according to the application!

ROBO WH 242 D, ROBO WH 455 D, ROBO WH 652 D TS

Wear parts

ROBO WH 242 D ROBO WH 455 D ROBO WH 652 D TS

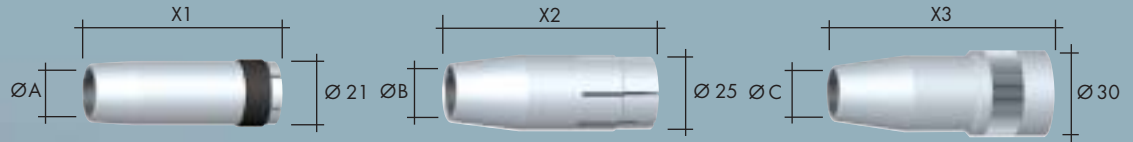

Gas nozzle (10 pcs.)	Ø A	X1	Ø B	X2	Ø C	X3
Conical (- 1.0 mm) ²⁾	Ø 13.0	62.0 mm	145.0135	Ø 13.0	-	-
Conical (- 1.5 mm) ²⁾	Ø 13.0	-	-	Ø 13.0	67.5 mm	145.0134
Conical (- 1.0 mm) ²⁾	Ø 15.5	62.0 mm	145.0090	Ø 15.5	-	-
Conical (- 1.5 mm) ²⁾	Ø 15.5	-	-	Ø 15.5	67.5 mm	145.0089
Bottle form (- 1.5 mm) ²⁾	Ø 15.5	-	-	Ø 15.5	67.5 mm	145.0164
Conical (+ 1.5 mm) ³⁾	Ø 15.5	-	-	Ø 15.5	64.5 mm	145.0106
Conical (- 1.,0 mm) ²⁾	Ø 18.0	-	-	Ø 18.0	-	-
Conical (- 1.0 mm) ²⁾	Ø 21.5	-	-	Ø 21.5	-	-

¹⁾ FLUSH = Gas nozzle flushed

²⁾ RECESS = Gas nozzle standing back

³⁾ STICK OUT = Gas nozzle protruding

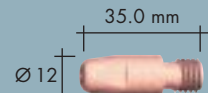
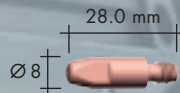

Contact tip (10 pcs.)	M6	M6	M8	M10
CuCrZr Ø 0.8	140.0054	140.0054	140.0117	-
Ø 0.9	140.0172	140.0172	140.0217	-
Ø 1.0	140.0245	140.0245	140.0316	140.0348
Ø 1.2	140.0382	140.0382	140.0445	140.0481
Ø 1.4	-	-	140.0536	140.0547
Ø 1.6	-	-	140.0590	140.0616

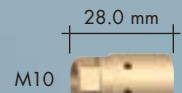
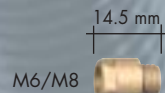
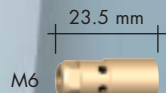

Contact tip holder (10 pcs.)	M6	M6/M8	M10
M6	142.0149	142.0123	-
M8	-	142.0122	-
M10	-	-	142.0145

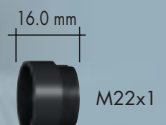
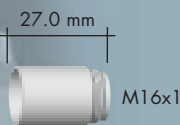

Nozzle insulator (10 pcs.)	M16x1	M18x1	M22x1
Standard	146.0066	146.0054	146.0056
High-temperature-resistant	-	146.0059	146.0069 (Ceramic)

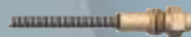

Neck liner	M16x1	M18x1	M22x1
for steel Ø 0.8-0.9	149.0073	149.0072	-
0° / 22° Ø 1.0-1.2	149.0077	149.0076	149.0080
Ø 1.4-1.6	-	149.0081	149.0083
for steel 45° Ø 0.8-0.9	149.0075	149.0074	-
Ø 1.0-1.2	149.0079	149.0078	149.0080
Ø 1.4-1.6	-	149.0082	149.0083
for Al Ø 0.8-1.0	149.0085	149.0084	149.0088
0° / 22° Ø 1.2-1.6	149.0090	149.0089	149.0093
for Al 45° Ø 0.8-1.0	149.0087	149.0086	149.0088
Ø 1.2-1.6	149.0092	149.0091	149.0093

MIG/MAG Welding Torches "WH and WH-PP" liquid-cooled

Cable assembly

Cable assembly "WH" cpl.

Length	L=1.05 m	L=1.15 m	L=1.25 m	L=1.45 m	L=1.65 m	L=2.15 m	L=2.65 m	L=3.15 m
Part-no.	965.2001	965.2002	965.2003	965.2004	965.2005	965.2006	965.2007	965.2008

Cable assembly "WH-PP" cpl. (gear ratio i=17,1:1 / Motor 42 V DC*)

Length	L=1.10 m	L=1.50 m	L=1.70 m	L=2.20 m	L=2.70 m	L=3.20 m
Part-no.	965.4014	965.4015	965.4016	965.4001	965.4002	965.4003

* The control cable is not pre-wired on the machine end. Power source specific types and lengths of more than 3,20 m on request.

Dimension "L"

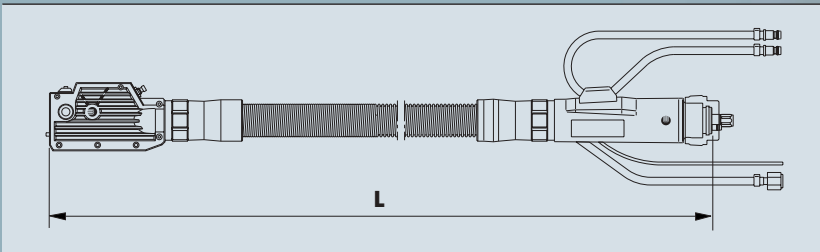

Liner		up to L=3.20 m	up to L=5.00 m
Liner red ¹⁾	Ø 0.8-1.2	124.0111	124.0113
Liner BSLblue ¹⁾	Ø 1.4-1.6	124.0108	124.0110
PA-Liner ²⁾	Ø 0.8-1.2	128.0012	128.0016
	Ø 1.4-1.6	128.0020	128.0030

¹⁾ **Red and BSLblue liner** (insulated) for the use of non-alloyed and low-alloyed steels. A totally insulated wire feed prevents damage caused by "micro-arcing" on the wire. This allows optimal current transfer inside the contact tip improving the welding process. The insulated steel liner must be used for power sources with optional welding wire sensors.

²⁾ **PA-Liner** for the use of aluminium and special wire types. Good feed ability properties and scratch resistance on the weld wire. Application temperature limit 150° C.

Drive Roll for WH-PP

	AI (U-Nut)	Universal (V-Nut)
Ø 0.8	961.0017	961.0269
Ø 0.9	961.0056	961.0270
Ø 1.0	961.0018	961.0227
Ø 1.2	961.0019	961.0228
Ø 1.4	-	961.0279
Ø 1.6	961.0020	961.0267

Mounting arm for connection to the Robot Mount CAT2

Clamp holder ³⁾
Adjustable TCP definition

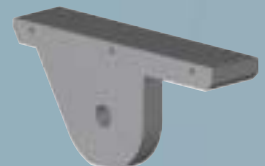

Segment holder ³⁾
Pre-defined angle in 15°-steps



³⁾ Order-No.: see table page 15

ROBO WH 242 D, ROBO WH 455 D, ROBO WH 652 D

Dimension sketch and alignment jigs

ROBO WH shown with standard holder

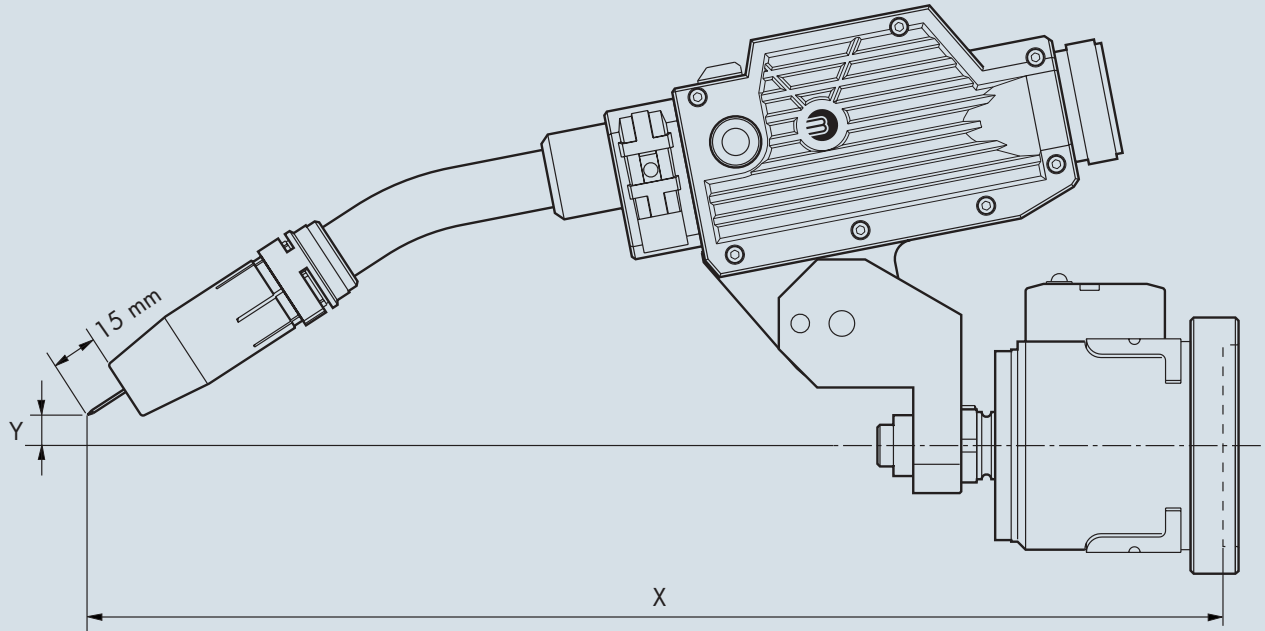

Mounting type	Torch	Torch geometrie	X	Y	Part-No.
WH standard adjustable	WH 242 D	22°	354	0	960.0026
	WH 242 D	45°	349	0	960.0026
	WH 455 D	22°	354	0	960.0026
	WH 455 D	45°	349	0	960.0026
	WH 652 D TS	22°	410	0	960.0026
	WH 652 D TS	45°	382	0	960.0026
Segment holder WH	WH 242 D	22°	variable in 15°-steps		780.0146
	WH 242 D	45°	variable in 15°-steps		780.0146
	WH 455 D	22°	variable in 15°-steps		780.0146
	WH 455 D	45°	variable in 15°-steps		780.0146
	WH 652 D TS	22°	variable in 15°-steps		780.0146
	WH 652 D TS	45°	variable in 15°-steps		780.0146

Alignment jig for torch type	for torch geometrie	Part-No.
ROBO WH 242 D	0°/22°/45°	837.0020
ROBO WH 455 D	0°/22°/45°	837.0020
ROBO WH 652 D	0°/22°/45°	837.0099



TIG Welding Torch System

“ABITIG® WH”

liquid-cooled

“Quick, safe and failure-free ...”

The ABITIG® WH-Welding-Torch-System from ABICOR BINZEL for TIG soldering and TIG welding offers a high process stability for joining various materials.

Preset tungsten electrodes, reproducible torch changes and maintenance service outside the robot cell guarantees constant high quality and continuous operation of the system.

With two sizes and different geometries, the TIG welding torch system ABITIG WH covers nearly all applications in the field of automated TIG welding and is suitable for welding even the most complicated parts. Also available as Push- or Push-Pull-Option with cold wire feeding.

- Flexible adaption on changing welding jobs
- Adjustable tungsten electrodes
- Reproducible torch position
- Cold wire feeding optional
- Liquid cooled up to 550 A
- Well proven and 100 % reliable

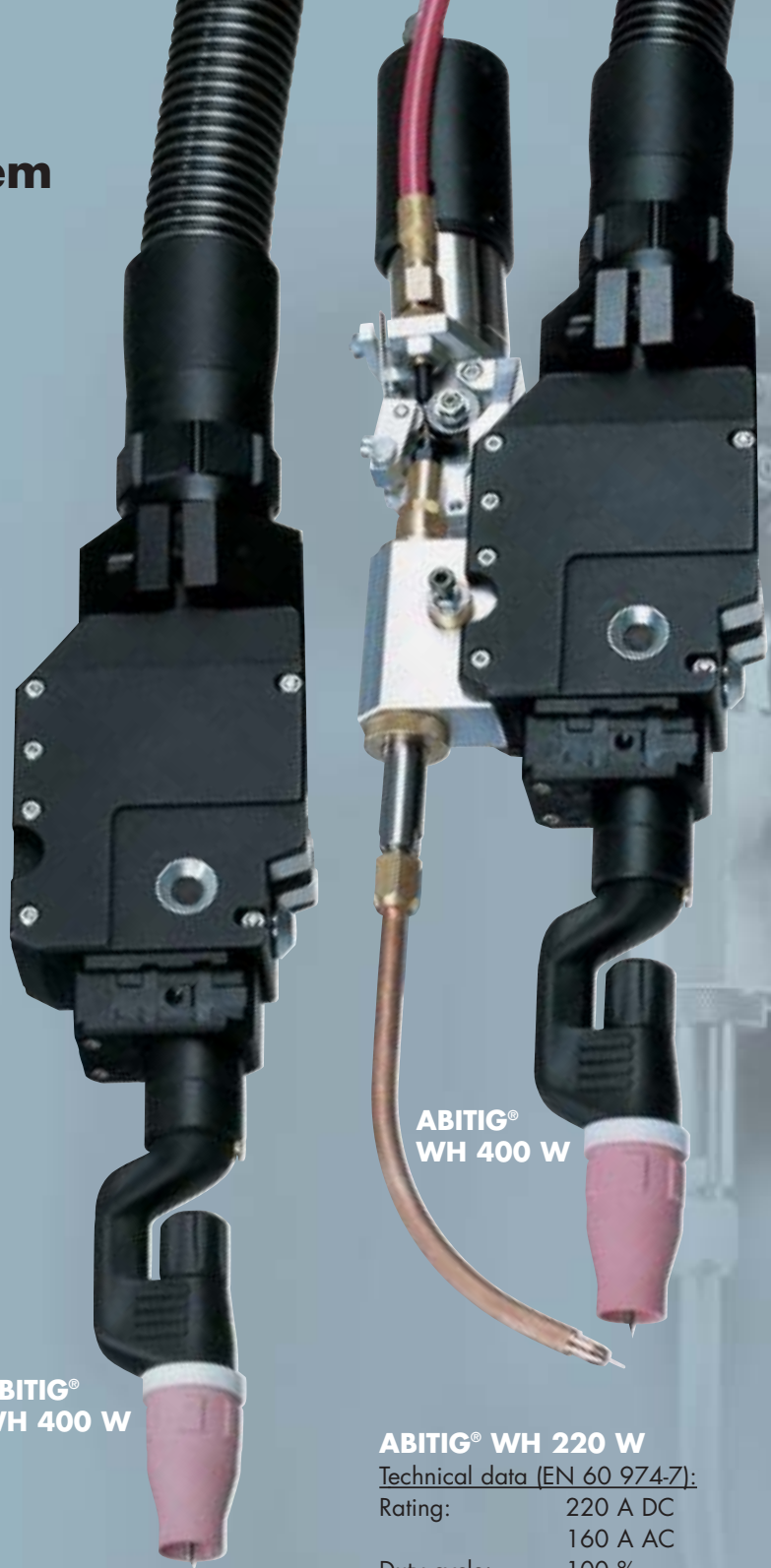

ABITIG® WH 400 W

ABITIG® WH 400 W

ABITIG® WH 220 W

Technical data (EN 60 974-7):

Rating:	220 A DC
	160 A AC
Duty cycle:	100 %
Wire size:	1.0–3.2 mm

ABITIG® WH 400 W

Technical data (EN 60 974-7):

Rating:	400 A DC
	280 A AC
Duty cycle:	100 %
Wire size:	1.6–4.8 mm

... fully automatic torch neck change - see page 26



Swan neck Type	Part-No.			
	0°	45°	70°	90°
ABITIG® WH 220 W	–	–	781.1001	–
ABITIG® WH 400 W	781.0504	781.0507	781.0501	781.0510







Wear and spare parts are not included in the delivery! Please order separately according to the application!

ABITIG® WH 220 W, ABITIG® WH 400 W



Wear parts

ABITIG® WH 220 W

ABITIG® WH 400 W

	ABITIG® WH 220 W		ABITIG® WH 400 W	
Back cap				
	776.0053		967.1351	
Electrode holder / Gas diffuser				
	Electrode holder (5 pcs.)	Gas diffuser (5 pcs.)	Electrode holder (5 pcs.)	Gas diffuser (5 pcs.)
Ø 1.0 mm	776.0061	776.0171	-	-
Ø 1.6 mm	776.0062	776.0172	775.0062	773.0172
Ø 2.0 mm	776.0067	776.0177	775.0067	773.0177
Ø 2.4 mm	776.0063	776.0173	775.0063	773.0173
Ø 3.2 mm	776.0064	776.0174	775.0064	773.0174
Ø 4.0 mm	-	-	775.0065	773.0175
Ø 4.8 mm	-	-	775.0066	773.0176

	ABITIG® WH 220 W		ABITIG® WH 400 W	
Insulator				
	776.1043		775.1043	
Gas nozzle, ceramic (10 pcs.)				
Ø 6.5 mm	777.0081	-	-	
Ø 7.5 mm	-	775.0081	-	
Ø 8.0 mm	777.0082	-	-	
Ø 9.5 mm	777.0083	-	-	
Ø 10.0 mm	-	775.0082	-	
Ø 11.0 mm	777.0084	-	-	
Ø 13.0 mm	-	775.0083	-	
Ø 15.0 mm	-	775.0084	-	

	ABITIG® WH 220 W		ABITIG® WH 400 W	
Gas nozzle, ceramic (10 pcs.)				
Ø 6.5 mm	777.2171	-	-	
Ø 7.5 mm	-	775.2171	-	
Ø 8.0 mm	777.2172	-	-	
Ø 9.5 mm	777.2173	-	-	
Ø 10.0 mm	-	775.2172	-	
Ø 11.0 mm	777.2174	-	-	
Ø 13.0 mm	-	775.2173	-	
Ø 15.0 mm	-	775.2174	-	

TIG Welding Torch System "ABITIG® WH" liquid-cooled

Cable assemblies and options

Cable assemblies cpl. version	Part-No.		
	L=4.00 m*	L=6.00 m*	L=8.00 m*
BCS-00 Standard	781.0526	781.0527	781.0528
BCS-03	781.0517	781.0518	781.0519
BCS-06	781.0523	781.0524	781.0525
BCS-08	781.0520	781.0521	781.0522

*Other versions on request.

BCS-00

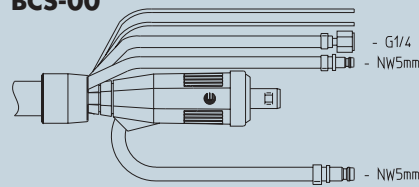

BCS-03

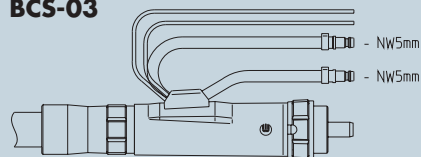

BCS-06

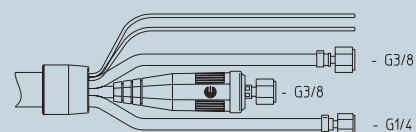

BCS-08

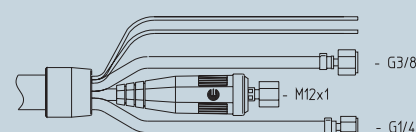

Options



Cold wire feeding

Description	Version / Specification	Part-No.
Cold wire feeding cpl.	incl. guide tube and -nozzle	967.0320
Guide tube	ABITIG® WH 220 W 70	967.0327
Guide tube	ABITIG® WH 400 W 0	967.0326
Guide tube	ABITIG® WH 400 W 45	967.0328
Guide tube	ABITIG® WH 400 W 70	967.0325
Guide tube	ABITIG® WH 400 W 90	967.0325
Guide nozzle	for wire size 0.6	967.0335
Guide nozzle	for wire size 0.8	967.0329
Guide nozzle	for wire size 1.0	967.0330
Guide nozzle	for wire size 1.2	967.0331
Guide nozzle	for wire size 1.6	967.0332
Wire conduit cpl.	4.00 m length	781.0514
Wire conduit cpl.	6.00 m length	781.0515
Wire conduit cpl.	8.00 m length	781.0516

Push-Pull Option

Description	Version / Specification	Part-No.
Push-Pull Option cpl. with Tacho-Motor	i=13.7:1 für $\Delta V = 1.1 - 8.0$ m/min	963.0120
Push-Pull Option cpl. with ENCODER-Motor	i=34.3:1 für $\Delta V = 0.2 - 5.0$ m/min	963.0253
Drive roll	for wire size 0.6	961.0268
Drive roll	for wire size 0.8	961.0269
Drive roll	for wire size 1.0	961.0227
Drive roll	for wire size 1.2	961.0228
Drive roll	for wire size 1.6	961.0267

Ignition aid

Description	Version / Specification	Part-No.
Ignition aid cpl.	ABITIG® WH 220 W	967.0102
Ignition aid cpl.	ABITIG® WH 400 W	967.0101

Bracket

Description	Version / Specification	Part-No.
Bracket	Connector for CAT2	963.0007

ABITIG® WH 220 W, ABITIG® WH 400 W

Dimension sketches and alignment jigs

ABITIG® WH 220 W

70°

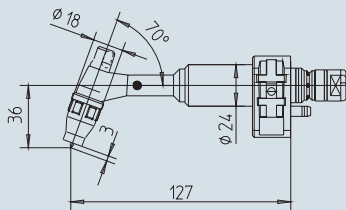

ABITIG® WH 400 W

0°

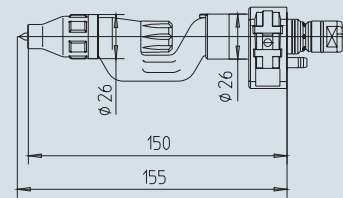

45°

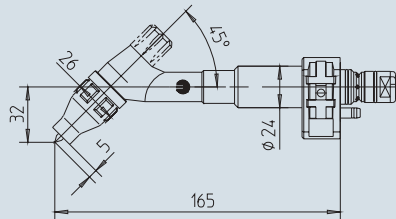

70°

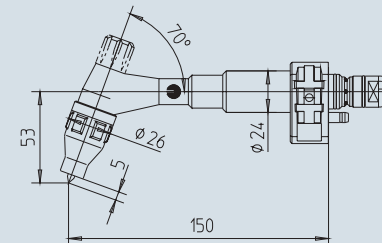

90°

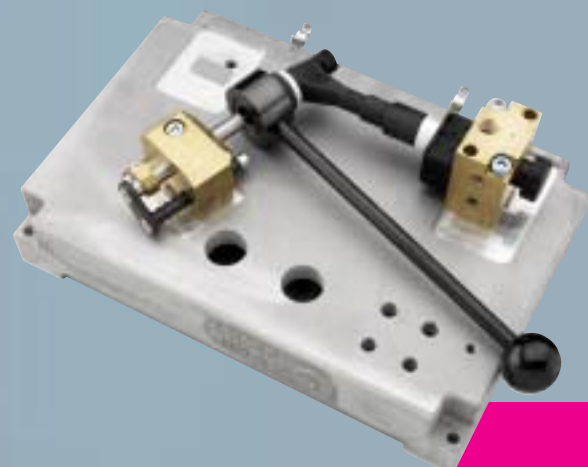
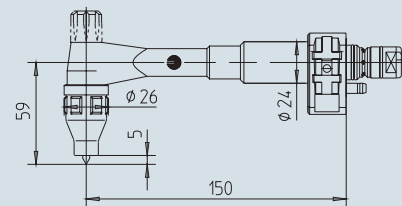

Alignment jig
for torch type

for torch
geometrie

Part-No.

ABITIG® WH 220 W 70° 837.0442

ABITIG® WH 400 W 0° / 70° 837.0440

ABITIG® WH 400 W 45° / 90° 837.0441

Robot mount "CAT2" – for safer welding

"To stop collisions quickly ..."

Faster robots, increasing dynamics, and thinner metals with complex outlines can lead to a collision of the torch to the workpiece. The **CAT2** robot mount protects against collisions with optimized resetting accuracy. Safety switch sensitivity can be user adjusted.

The wide range of accessories gives the **CAT2** a multitude of mounts and extensions for realising the desired TCP.

- Variable deflection in every position
- Instantaneous stop in case of collision
- Precise repeatability minimizes downtime
- Precise switch points by innovative switching-time response
- Perfect for ultrahigh accuracy, light gauge sheet metal operations
- Easy to service by visual multi-functional display for a quick error analysis
- Covered screws for quick service
- Adaptable to all robot types and handling systems – by adapter flange (plastic or aluminium)



Technical data:

Robot mount "CAT2"

Dimensions:	Corner width 75 mm; Across flats 65 mm; height 87 mm (robot flange > release flange)
Weight:	approx. 630 g approx. 850 g (incl. tool holder and flange)
Release force:	please look at the chart
Max. excursion:	in X- and Y-plane against each spring 10 - 14°; in Z-plane against each spring 4 - 8 mm
Instantaneous stop release:	Through Z-axis 0.5° - 1°; Deviation through X- and Y-direction approx. 1.5°; Deviation through Z-direction approx. 0.5 - 1 mm
Repeatability:	< +/- 0.04 mm (at 300 mm stand-off from robot flange)
Safety switch:	24 V DC, max. 100 mA

Robot mount "CAT2"

Deflection of the CAT2:

- Collision in direction of the X- or Y-axis
- Rotation around the Z-axis
- Collision in direction of the Z-axis

The release torque is defined by the spring types, depending on application and weight of the torch. There are five spring types available – see table.

Release force (N)

Spring-type	Release force X-, Y-axis (N)	Release force Z-axis (N)
S	46	475
M	80	535
L	85	925
LL	130	1325
XL	150	1540



Robot mount CAT2

Description	Part-No.
Robot mount CAT2 CAT2 (S) cpl. ¹⁾	780.2131
Robot mount CAT2 (M) cpl. ¹⁾	780.2100
Robot mount CAT2 (L) cpl. ¹⁾	780.2121
Robot mount CAT2 (LL) cpl. ¹⁾	780.2118
Robot mount CAT2 (XL) cpl. ¹⁾	780.2132
Robot mount CAT2 (S)	780.2031
Robot mount CAT2 (M)	780.2001
Robot mount CAT2 (L)	780.2021
Robot mount CAT2 (LL)	780.2038
Robot mount CAT2 (XL)	780.2032
Holder	780.0202
Spiral cable cpl.	780.0201
Universal TCP Check Tool for CAT2	780.0204

¹⁾Cpl. with holder (780.0202) and helix cable (780.0201)

Adapter flange

Description	Plastic type Part-No.	Aluminium type Part-No.
ISO 9409-1-A31.5	780.0632	780.0532
ISO 9409-1-A40	780.0604	780.0504
ISO 9409-1-A50	780.0603	780.0503
ISO 9409-1-A63	780.0614	780.0514
ISO 9409-1-A80	780.0607	780.0507
ISO 9409-1-A100	780.0649	780.0549
ISO 9409-1-A125	780.0630	780.0530

Adapter flanges can be delivered for all common welding robots. Please indicate the type of robot and model of robot.

Attention! Due to insulation reasons always apply plastic adapter flange when using MIG/MAG welding torches of the **ABIROB® A** product series.

ABIROB® A 360 with Robot mount CAT2

Torch cleaning station "BRS-CC"

"Plug and Play ..."

... the complete solution for reliable automatic servicing of the torch neck. Installed quickly and easily, or **"Plug and Play ..."**, the compact torch cleaning station BRS-CC means top reliability. Combined in a single station, the 3 systems guarantee optimally timed processes and an increase in available plant floor space. A number of other features such as mounting stand and drip pan reduce installation costs.

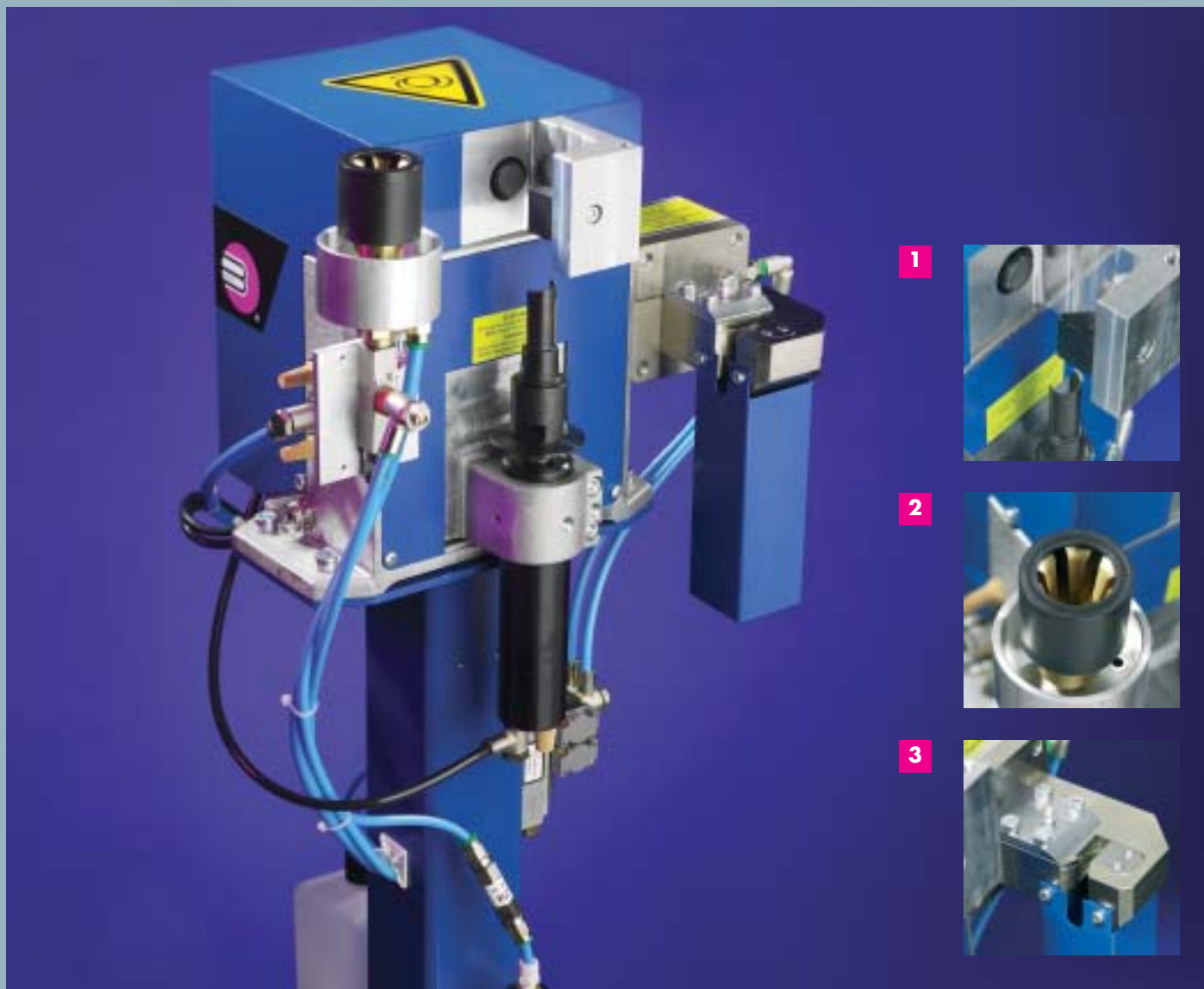

1. Torch cleaning station

- Precise and effective cleaning for almost all robot welding torches
- Proven and trusted cutter principle, suitable even for heavy spatter adhesion
- 3-point clamping of the gas nozzle fixes the torch in place during the cleaning process

2. Spraying unit "TMS-VI"

- Direct, economical spraying of anti-spatter fluid reduces welding spatter adhesion and extends the servicing intervals
- Clean environment thanks to encapsulated spraying nozzle and collecting pan for dirty residual oil

- Simple disposal of residual oil and replenishment of the anti-spatter agent by simply exchanging the bottles

3. Wire cutting fixture „DAV“

- The combined clamping and shearing action guarantees precise cutting quality and ensures optimum arc-start properties as well as exact TCP measurement
- Long service life thanks to sturdy design

Torch cleaning station "BRS-CC"

Description	Part-No.
Torch cleaning station "BRS-CC" cpl.	831.0490
Torch cleaning station "BRS-CC" without "DAV"	831.0550

Torch cleaning station "BRS-CC"

V-Block and reamer

For torch type	with gas nozzle	Outer-Ø / nominal-Ø (mm)	Length (mm)	with contact tip	Clamping block Part-No.	Reamer Part-No.
ABIROB® A 360	145.0599	22.0 / 12.0	68.0	M6 / Ø 8	831.0371	831.0604
ABIROB® A 360	145.0600	22.0 / 12.0	70.0	M6 / Ø 8	831.0371	831.0604
ABIROB® A 360	145.0601	22.0 / 12.0	65.0	M6 / Ø 8	831.0371	831.0604
ABIROB® A 360	145.0595	22.0 / 14.0	68.0	M6 / Ø 8	831.0371	831.0592
ABIROB® A 360	145.0596	22.0 / 14.0	70.0	M6 / Ø 8	831.0371	831.0618
ABIROB® A 360	145.0597	22.0 / 14.0	65.0	M6 / Ø 8	831.0371	831.0593
ABIROB® A 360	145.0618	22.0 / 14.0	68.0	M6 / Ø 8	831.0371	831.0592
ABIROB® A 360	145.0619	22.0 / 14.0	65.0	M6 / Ø 8	831.0371	831.0593
ABIROB® A 360	145.0592	22.0 / 16.0	68.0	M6 / Ø 8	831.0371	831.0487
ABIROB® A 360	145.0593	22.0 / 16.0	70.0	M6 / Ø 8	831.0371	831.0487
ABIROB® A 360	145.0594	22.0 / 16.0	65.0	M6 / Ø 8	831.0371	831.0589
ABIROB® A 500	145.0589	28.0 / 13.0	75.0	M6 / Ø 8	831.0318	831.0180
ABIROB® A 500	145.0590	28.0 / 13.0	77.0	M6 / Ø 8	831.0318	831.0180
ABIROB® A 500	145.0591	28.0 / 13.0	72.0	M6 / Ø 8	831.0318	831.0169
ABIROB® A 500	145.0586	28.0 / 14.0	75.0	M6 / Ø 8	831.0318	831.0592
ABIROB® A 500	145.0587	28.0 / 14.0	77.0	M6 / Ø 8	831.0318	831.0618
ABIROB® A 500	145.0588	28.0 / 14.0	72.0	M6 / Ø 8	831.0318	831.0593
ABIROB® A 500	145.0580	28.0 / 16.0	75.0	M8 / Ø 10	831.0318	831.0488
ABIROB® A 500	145.0581	28.0 / 16.0	77.0	M8 / Ø 10	831.0318	831.0488
ABIROB® A 500	145.0582	28.0 / 16.0	72.0	M8 / Ø 10	831.0318	831.0591
ABIROB® A 500	145.0583	28.0 / 16.0	75.0	M8 / Ø 10	831.0318	831.0488
ABIROB® A 500	145.0584	28.0 / 16.0	77.0	M8 / Ø 10	831.0318	831.0488
ABIROB® A 500	145.0585	28.0 / 16.0	72.0	M6 / Ø 8	831.0318	831.0591
VTS 290	145.0495	25.0 / 13.0	44.5	M6 / Ø 8	831.0316	831.0169
VTS 290	145.0564	25.0 / 13.0	48.5	M6 / Ø 8	831.0316	831.0180
VTS 290	145.0494	25.0 / 15.5	44.5	M6 / Ø 8	831.0316	831.0576
VTS 500TS	145.0479	25.0 / 13.0	75.5	M8 / Ø 10	831.0316	831.0368
VTS 500TS	145.0556	25.0 / 13.0	77.0	M8 / Ø 10	831.0316	831.0368
VTS 500TS	145.0466	25.0 / 15.5	72.0	M8 / Ø 10	831.0316	831.0216
VTS 500TS	145.0568	25.0 / 15.5	72.5	M8 / Ø 10	831.0316	831.0216
VTS 500TS	145.0553	25.0 / 15.5	75.5	M8 / Ø 10	831.0316	831.0023
VTS 500TS	145.0544	25.0 / 15.5	75.5	M8 / Ø 10	831.0316	831.0023
VTS 500TS	145.0480	25.0 / 15.5	77.0	M8 / Ø 10	831.0316	831.0023
WH 242 D	145.0135	21.0 / 13.0	62.0	M6 / Ø 8	831.0314	831.0564
WH 242 D	145.0090	21.0 / 15.5	62.0	M6 / Ø 8	831.0314	831.0563
WH 455 D	145.0134	25.0 / 13.0	67.5	M8 / Ø 10	831.0316	831.0413
WH 455 D	145.0106	25.0 / 15.5	64.5	M8 / Ø 10	831.0316	831.0216
WH 455 D	145.0089	25.0 / 15.5	67.5	M8 / Ø 10	831.0316	831.0023
WH 455 D	145.0164	25.0 / 15.5	67.5	M8 / Ø 10	831.0316	831.0023
WH 652 D TS	145.0574	30.0 / 18.0	84.0	M10 / Ø 12	831.0319	831.0162
VTS 652 D TS	145.0575	30.0 / 21.5	84.0	M10 / Ø 12	831.0319	831.0547

Technical data:

Pneumatic connection – manifold block

Compressed air supply outlet: G 1/4
 Inside width: min. Ø 6 mm
 Nominal pressure: 6 bar
 Operating pressure: 6–8 bar

Electrics – terminal block

4 inlets for triggering the 5/2-control valves
 Control voltage: 24 V DC
 Power demand: 4.5 W
 1 inductive proximity switch a-contact (pnp)
 Operating voltage: 10–30 V DC
 Tolerated residual ripple: V_{ss} < 10%
 Continuous current: max. 200 mA
 Current consumption: ca. 4 mA (24 V)
 Voltage drop: ca. 1.2 V (200 mA)

Cleaning station

Pneumatic motor (nominal speed)
 - with lubricated air: approx. 650 rpm
 - without lubricated air: approx. 550 rpm
 Air consumption: approx. 380 l/min.

Injection unit

Capacity of the bottle: 1 litre

Wire cutting station

Cutting rate at 6 bar
 - Solid wire: up to 1.6 mm
 - Flux-cored wire: up to 3.2 mm
 Cutting time: 0.5 sec.

General data

Weight: approx. 16 kg
 Ambient temperature: + 5°C up to + 50°C

Front injector "ABIROB® TMS-VI"

"For the reduction of spatter adhesion ..."

With the **front injector ABIROB® TMS-VI** the cleaned torch is sprayed with anti spatter fluid which minimizes built-up of welding spatter. The specially developed spray nozzle enables a highly efficient application of the anti spatter fluid.

Front injector ABIROB® TMS-VI – this new concept enables a smooth and economical spraying of the anti spatter fluid to the front of the welding torch.

The advantages at a glance:

- Effective and economical anti spatter spray supply to nozzle interior and nozzle edge
- Covered injector nozzle and extra bottle for used oil improves working safety and ensures environmental friendly use
- Trouble-free refilling of the anti spatter fluid, simply by swapping the bottle.
- Trouble-free dispose of used oil by swapping the bottle
- Installation set for a user-friendly installation of the unit



Technical data:

Pneumatics

Working pressure: 5 – 10 bar
Internal dia.: ø 4 mm

5/2 solenoid valve

Air connection: G 1/8"
Nonimal flow: approx. 650 l/min.
Input signal: 24 V DC
I max. ≤ 1.1 A
I nom. = 220 mA

Front injector TMS-VI

Description	Part-No.
Front injector TMS-VI cpl.	830.1110
Solenoid valve* pilot-controlled (NW 10) 24 V DC / 42 V AC	832.0005
Anti-spatter-fluid 1 Litre	192.0056
Anti-spatter-fluid 5 Litre	192.0052
Anti-spatter-fluid 20 Litre	192.0048
Anti-spatter-fluid 200 Litre	192.0046

* Optional for blasting through the cable assembly.

Wire cutting station "DAV"

"The perfect cut ..."

The wire cutting station DAV in MIG/MAG robotic welding is an essential requirement to guarantee a consistent wire stick-out, and clean end of the wire as well as better capacity of arc-start due to the cutting of the welding ball and oxides formed at the end of the wire.

The ABICOR BINZEL wire cutting station DAV stands for:

- Defined wire length as requirement for the automatic TCP measurement
- Precise and reliable cutting quality even with hard or thick wires
- High durability and longevity of the blades
- Wire clamping function for the wire removal in connection with the ATS-Rotor



Technical data:

Wire cutting station "DAV"

Working pressure: 6 – 8 bar
 Air connection: ID 4.0 mm
 Cutting range at
 6 bar: Solid wire 1.6 mm
 Cored wire 3.2 mm
 Weight: 2700 g

Extension set

Working pressure: 6 – 8 bar
 Air connection: G 1/8"
 Control requirements: 24 V DC
 I max. = 1.1 A peak
 I ave. = 220 mA cont.
 Weight: 265 g

Wire cutting station "DAV"

Description	Part-No.
Wire cutting station "DAV" cpl.	839.0020
Replacement knife	839.0024
Replacement static blade	839.0026
Extension set consisting of: 5/2-way-valve, plug, connectors, pneumatic hose (1m) and silencer	839.0035

“ATS-ROTOR” – the intelligent system for the automatic exchange of the WH torch necks (MIG and TIG)

“Work around the clock ...”

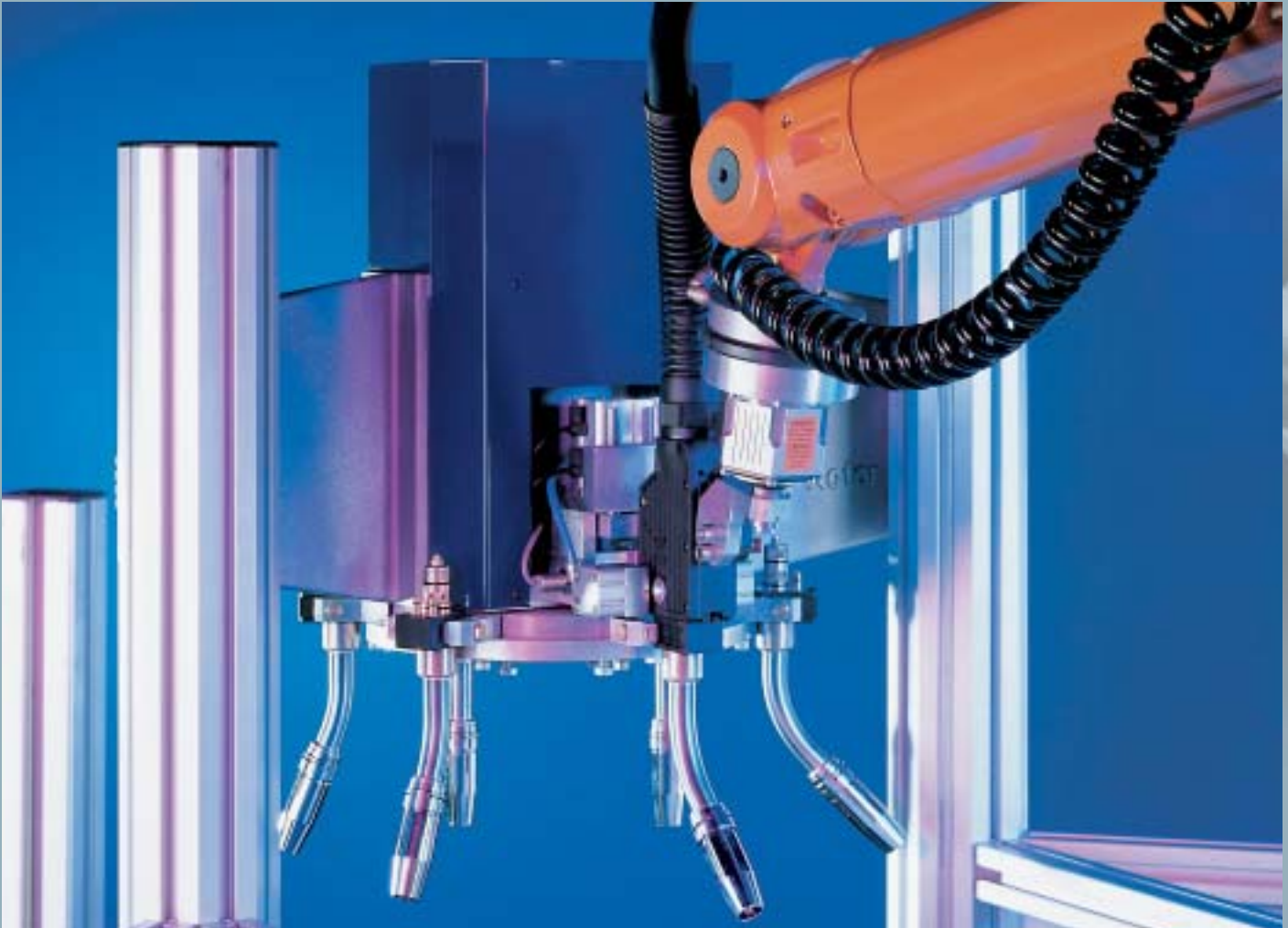

Integrated into the robot cell the ATS rotor can be equipped with up to five replacement torch necks. The factory standardized interface enables the application of MIG/MAG- and TIG-neck changes. Depending on the welding application the robot accesses the neck change system cyclically and event-oriented (for example a stuck torch) to exchange a torch neck with a new torch neck.

Only after exchanging all five change necks (in a cyclical exchange) a manual action needs to be done by equipping the ATS rotor with newly serviced necks. Exchanging of the spare and wear parts on the torch necks is performed outside the robot cell, while the production process continues.

This means to the user an enormous potential (up to the fivefold) of the availability of the unit (referring to the maintenance service at the torch neck).

- System for an automatic torch neck changing, unique world wide
- Simple aluminium cast frame with low-maintenance pneumatic cylinder
- Integrated SPS (industry standard) for the connection at the robot control system
- Easy to install and use

Technical data:

Dimensions: 660 mm width,
416 mm height (plus 100 mm lift) – for more detailed information please refer to separate data-sheet

Weight: approx. 31 kg

Ambient temp.: 5°- 50°C

Protection class: I (DIN 57 106)

Pneumatic data

Connection: G1/4"

Internal dia: min. Ø 6 mm

Rated pressure: 6 bar

Consumption per

change:

Electrical data

Operating voltage: 24 V DC

Power consumption: 50 W

W Max. ripple: V_{ss}<10%

Functioning

The robot controls the ATS-Rotor through the use of 24 V digital inputs and outputs. Each individual change cycle is performed automatically under the control of an integrated PLC.



1 Robot docks WH neck into ATS-Rotor change station.



2 Neck release mechanism is engaged and wire is cut inside the torch body.



3 The change neck is taken off by the downward movement of the rotor plate. Quick release valves in the water channels avoid leaking of the coolant.



4 Rotor carousel rotates a replacement neck into position.



5 Replacement neck is locked into position. All supply connectors are automatically made, robot moves out of change station and continues.

ATS-Rotor

Description	Part-No.
ATS-Rotor with SPS	840.3300
ATS-Rotor without SPS	840.3400

Welding accessories

To achieve the best results ...

... one of the things which will help you to achieve the best results in the welding process is to use professional accessories. When ideally tailored to the task, they provide the basis for operational safety and long service life. High-quality welding accessories increase the output and reliability of your torch. To achieve optimum results, don't leave anything to chance. Rely on original welding accessories from ABICOR BINZEL.

1 Anti spatter fluid, silicon free, protect for spatter Part-No.:

1 litre	192.0056
5 litre	192.0052
20 litre	192.0048
200 litre	192.0046



2 Gas flow meter Part-No.: 191.0003

3 Wire cleaning felt red for steel (Set) Part-No.: 193.0001 white for Al (Set) Part-No.: 193.0002

Wire cleaning felt red for steel (25 pcs.) Part-No.: 193.0003 white for Al (25 pcs.) Part-No.: 193.0004

4 Clamp Part-No.: 193.0007



5 Special coolant BTC-15 The special coolant from BINZEL – protect down to minus 10°C for all liquid welding and cutting facilities. Part-No.:

5 litre	192.0110
20 litre	192.0111
200 litre	192.0112



6 Spigot Part-No.: 192.0109 for 200 litre barrel

7 Accessory case big Part-No.: 192.0069 8 Accessory case small Part-No.: 192.0066



9 Spanner Part-No.: 191.0001 10 Multiple spanner Part-No.: 191.0015 11 Universal spanner Part-No.: 750.0125 12 Electrode spanner Part-No.: 743.0064

Not shown. Socket wrench SW 6 Part-No.: 191.0103 Socket wrench SW 8 Part-No.: 191.0102 Socket wrench SW 10 Part-No.: 191.0104



13 Sharpener for collet core liner Part-No.: 191.0064 14 Hose cutter for PA-Liner Part-No.: 191.0062

15 Cable assembly support Part-No.: 191.0039



16 Protective cover 1.20 m Part-No.: 191.0040 Protective cover ABIROB® A Part-No.: 191.0161 (not shown)

Not shown. Alignment tool Part-No.: 191.0090 Cutter for nozzle insulators M10x1 Part-No.: 191.0085

Coolant recirculator WK 23 / WK 43

The portable cooling device for all common applications!

- **Simple handling**
Connection (feed and return) via quick-action couplings.
- **Compact design size**
Small space requirements.
- **Sturdy design**
Indestructible stainless steel tank and sturdy housing.
- **Service-friendly**
Clear coolant sight glass.

■ **Cool supplement:**
Liquid-cooled welding with air-cooled power sources



WK 23

WK 43

Technical data:

Type	WK 23	WK 43
Heat exchanger:	2 lines	4 lines
Immersion pump 50 Hz (protection class IP 54)	Delivery height: Hmax. 32 m Delivery height at G3/8" connector: Qmax. 13.5 litres per min.	Delivery height: Hmax. 32 m Delivery height at G3/8" connector: Qmax. 13.5 litres per min.
Immersion pump 60 Hz (protection class IP 54)	Delivery height: Hmax. 32 m Delivery height at G3/8" connector: Qmax. 16.0 litres per min.	Delivery height: Hmax. 32 m Delivery height at G3/8" connector: Qmax. 16.0 litres per min.
Cooling capacity (RT = 22° C)	ca.1000 W at 1 litre per min.	ca.1300 W at 1 litre per min.
Dimensions (LxBxH)	253x270x460 mm	253x270x516 mm
Weight:	17 kg	18 kg
Tank capacity:	7 litres	7 litres

Type	Line Voltage	Frequency	Power rating	Current consumption	Part-No.
WK 23	115 V	50 Hz	0.35 kW	6.5 A	850.0214
WK 23	115 V	60 Hz	0.35 kW	6.5 A	850.0135
WK 23	230 V	50 Hz	0.35 kW	3.1 A	850.0137
WK 23	230 V	60 Hz	0.35 kW	3.1 A	850.0210
WK 23	240/415 V	50 Hz	0.50 kW	2.6/1.6 A	850.0144
WK 43	115 V	50 Hz	0.35 kW	6.5 A	850.0215
WK 43	115 V	60 Hz	0.35 kW	6.5 A	850.0156
WK 43	230 V	50 Hz	0.35 kW	3.1 A	850.0159
WK 43	230 V	60 Hz	0.35 kW	3.1 A	850.0211
WK 43	240/415 V	50 Hz	0.50 kW	2.6 A/1.6 A	850.0165

Operating instructions

As coolant for all liquid-cooled torch systems, we recommend the special BINZEL coolant BTC-15, which remains liquid down to -10°C. Must be used in conjunction with an adequate motor protection device! A water flow cut-off switch (850.0033) is recommended!

Notes

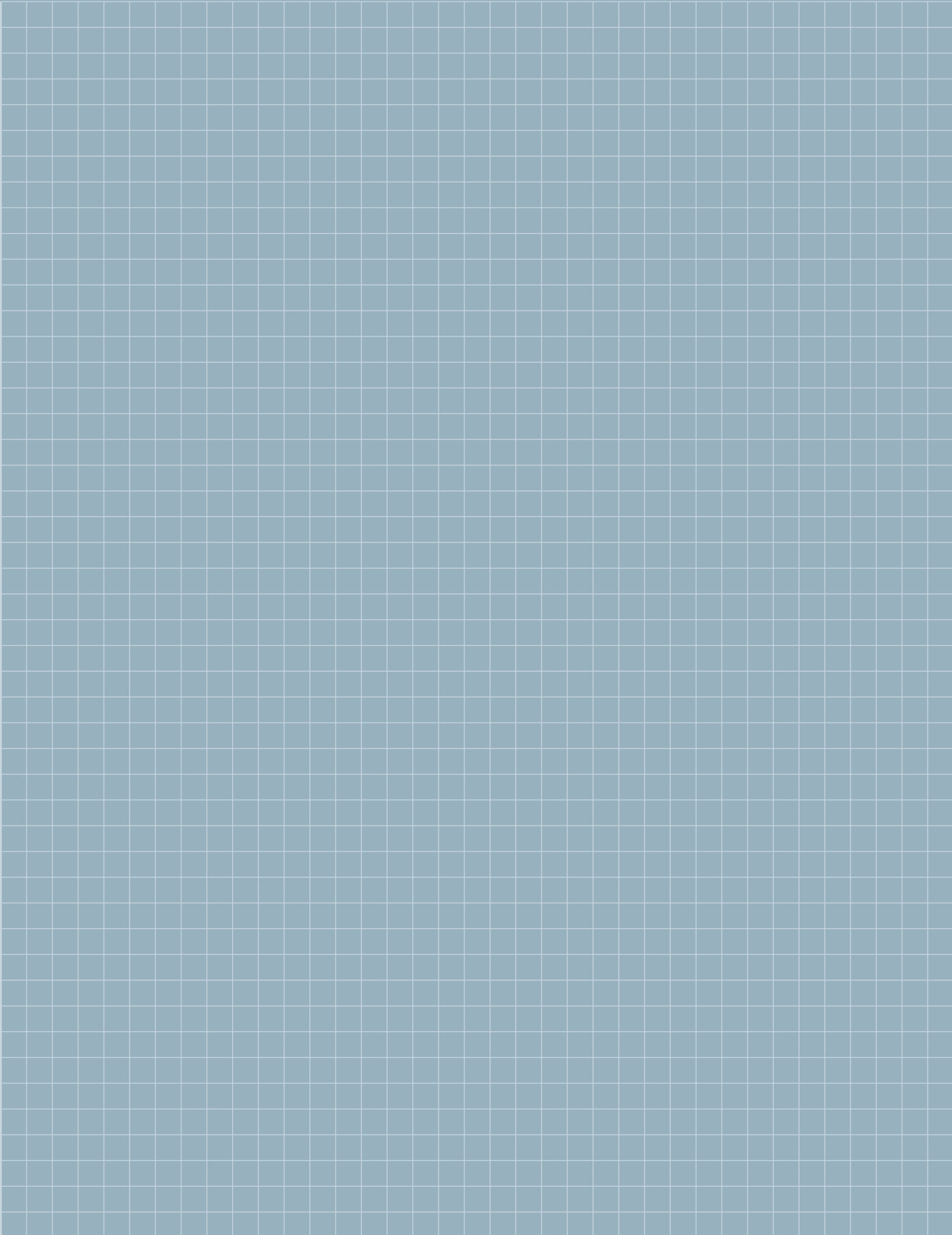

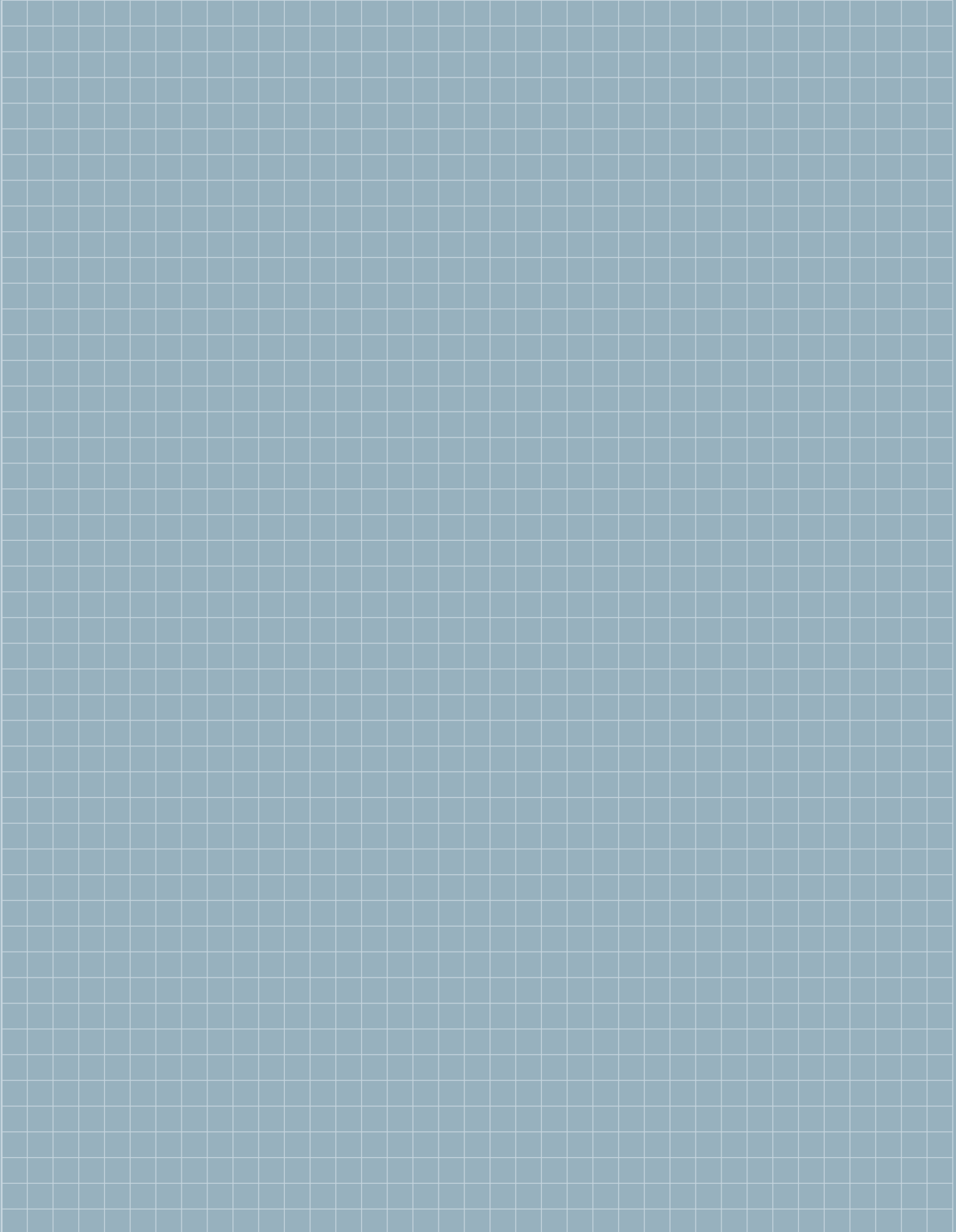



Technology for the Welder's World.

Our product range:

■ MIG/MAG

- Welding Torches
- Automatic and Special Torches
- Push-Pull Welding Torches
- Fume Extraction Torches
- Central Adaptor System

■ TIG

- Welding Torches
- Automatic and Special Torches

■ PLASMA

- Cutting Torches
- Welding Torches
- Automatic and Special Torches

■ Robotic Peripheral Equipment

- Robot Torches
MIG/TIG/Plasma
- Robot Mount CAT2
- Torch Change System ATS-Rotor
- Tool Change System WWS
- Wire Cutting Station DAV
- Torch Cleaning Station
BRS-LC and BRS-FP
- Wire Feeding Station APD-MF

■ Welding Accessories

- Cooling Device
- Welding Cable Plug and Socket
- Anti Spatter Spray and Paste
and so on ...



Alexander Binzel Schweisstechnik GmbH & Co. KG
P.O. Box 10 01 53 · D-35331 Gießen
Phone: ++49 (0) 64 08 / 59-0
Fax: ++49 (0) 64 08 / 59-191
Internet: www.binzel-abicor.com